

iDS-TCS402-B/CS

Radar-Assisted Traffic Camera



- Applicable to low speed measurement scenarios, like campus, industrial park, residence, and so on.
- Integrated with millimeter wave radar and 4 MP low illumination camera.
- The real-time speed of vehicles and license plate number can be displayed on the linked screen.
- Max. 100 m speed detection distance, and max. 22 m license plate recognition distance.
- Defog, HLC, WDR, and multiple white balance modes, satisfying various scenes.
- Lane coverage: 3 lanes (ANPR & speed measurement), and speed detection range: 0-120 km/h.
- Supports license plate recognition and vehicle features recognition (vehicle type, vehicle color, no-plate vehicle capture, moving direction detection, etc).
- Free of influences from natural conditions such as illumination, visibility, bad weather, etc.



▪ Specification

Camera	
Max. Resolution	2688 × 1520
Min. Illumination	Color: 0.01 Lux @ (F1.2, AGC ON) B/W: 0.001 Lux @ (F1.2, AGC ON)
Shutter Time	1/25 s to 1/100,000 s
Lens	
Focus	16 mm
Illuminator	
External Supplement Light	Continuous LED supplement light
Supplement Detection (Radar)	
Speed Range	0 to 120 km/h
Max. Detectable Targets	Able to track and detect max. 128 targets
Video	
Main Stream	50 Hz: 25 fps (2688 × 1520, 1920 × 1080, 1280 × 720, 704 × 576, 352 × 288) 60 Hz: 30 fps (2688 × 1520, 1920 × 1080, 1280 × 720, 704 × 576, 352 × 288)
Sub Stream	50 Hz: 25 fps (1920 × 1080, 1280 × 720, 704 × 576, 352 × 288) 60 Hz: 30 fps (1920 × 1080, 1280 × 720, 704 × 576, 352 × 288)
Video Compression	H.265/H.264
Video Bit Rate	32 Kbps to 16 Mbps
Network	
Protocols	TCP/IP, HTTP, DNS, RTP, RTSP
Image	
Image Settings	White Balance (Auto)
Frame Rate	25 fps
Day/Night Switch	ICR
Image Enhancement	3D DNR
Interface	
Video Output	1-ch level output
Ethernet Interface	2, RJ45 100M/1000M self-adaptive Ethernet interface
On-board Storage	TF card slot
RS-485	1
RS-232	1
Road Traffic and Vehicle Detection	
Coverage	3 lanes
Smart Function	License plate recognition (LPR); Vehicle feature recognition: vehicle type classification, vehicle color recognition, no-plate vehicle capture, moving direction detection

LPR Countries/Regions	<p>Mid-East: United Arab Emirates (Abu Dhabi, Fuchaiha, Dubai, Cape Haima, Ozhman, Sharjah, Umgavan), Qatar, Iran, Iraq, Egypt, Jordan, Kuwait, Saudi Arabia, Pakistan, Oman, Lebanon, Bahrain</p> <p>Africa: Nigeria, Kenya, Cote d'Ivoire, South Africa, Tanzania, Mauritius, Morocco, Tunisia, Sierra Leone, Zambia, Ghana, Zimbabwe, Uganda, Angola, Ethiopia, Senegal, Algeria</p> <p>Asia-Pacific: Australia, New Zealand, Indonesia, Malaysia, Singapore, South Korea, Thailand, Vietnam, Philippines, Hong Kong, Macao, Taiwan, Burma, India, Mongolia, Cambodia, Laos, Bangladesh</p> <p>America: United States of America, Canada, Argentina, Chile, Paraguay, Uruguay, El Salvador, Bolivia, Colombia, Brazil, Ecuador, Peru, Mexico, Panama, Costa Rica, Trinidad and Tobago, Dominican, Guatemala</p> <p>Europe: Turkey, Croatia, Slovakia, Czech Republic, Bulgaria, Macedonia, Hungary, Greece, Poland, France, Netherlands, Switzerland, Spain, Britain, Ireland, Germany, Italy, Austria, Israel, Palestine, Belgium, Luxembourg, Albania, Kosovo</p> <p>Russian-Speaking Regions: Azerbaijan, Belarus, Kazakhstan, Lithuania, Georgia, Estonia, Latvia, Russian Federation, Ukraine, Moldova, Uzbekistan, Kyrgyzstan, Armenia</p>
Accuracy (Under recommended installation and lighting conditions)	<p>Capture rate $\geq 98\%$</p> <p>Vehicle moving direction recognition accuracy $\geq 98.5\%$</p> <p>LPR accuracy $\geq 98\%$</p> <p>Mistaken capture rate $\leq 2\%$</p>
Vehicle Type	Car/Van/Bus/Truck/Light Truck/SUV_MPV/Pickup/Pedestrian/Motorcycle/Tricycle
Vehicle Color	Red, yellow, green, blue, pink, purple, cyan, brown, white, grey, black Recognizable at daytime only
Vehicle Manufacturer	84 manufacturers: Hyundai, Toyota, KIA, Honda, Volkswagen, Benz, Nissan, Ford, Isuzu, BMW, Chevrolet, Mitsubishi, Renault, Opel, Suzuki, Skoda, Daewoo, Audi, Mazda, GAC HINO, Peugeot, SsangYong, Citroen, Fiat, Scania, MAN, Volvo, Lexus, Seat, Land Rover, Daihatsu, Dongwo, Subaru, Iveco, MINI, JEEP, Porsche, Chery, Dodge, Chrysler, Acura, Alfa Romeo, Great Wall, Infiniti, Smart, Saic Maxus, JAC, Jaguar, GMC, Lincoln, JMC, SAAB, FAW, Yutong, Guangzhou Yunbao, Joylong, Geely, Cadillac, JBC, An'kai, Haima, Foton, King Long, Dongfeng, Geely-Emgrand, Perodua, UD, BYD, Renault Samsung, Proton, HICOM, Malaysia_Unknown 1, Hyundai-Rohens, SsangYong-Old Version, Equus-Old Version, CNHTC, Rolls-Royce, Beiben Truck, Haval, Hino, Kia-Borrego, Chang'an, Alfa, FORO
General	
Power	24 VAC $\pm 10\%$, Max. 15 W
Dimension	226 \times 206.4 \times 375.3 mm (8.9 \times 8.1 \times 14.8 inch)
Weight	3 kg
Operating Condition	-30 $^{\circ}$ C to 70 $^{\circ}$ C (-22 $^{\circ}$ F to 158 $^{\circ}$ F); Humidity 95% or less (non-condensing)
General Function	Heartbeat, password protection, NTP time synchronization

Approval

Safety	User name and password authentication, HTTPS digital certification
Protection	IP66
Other	Supports hardware watchdog

▪ Available Model

iDS-TCS402-B/CS/16

**Please decide whether to use anti-corrosion devices or matched hoops and brackets according to the actual working environment.*

▪ Dimension

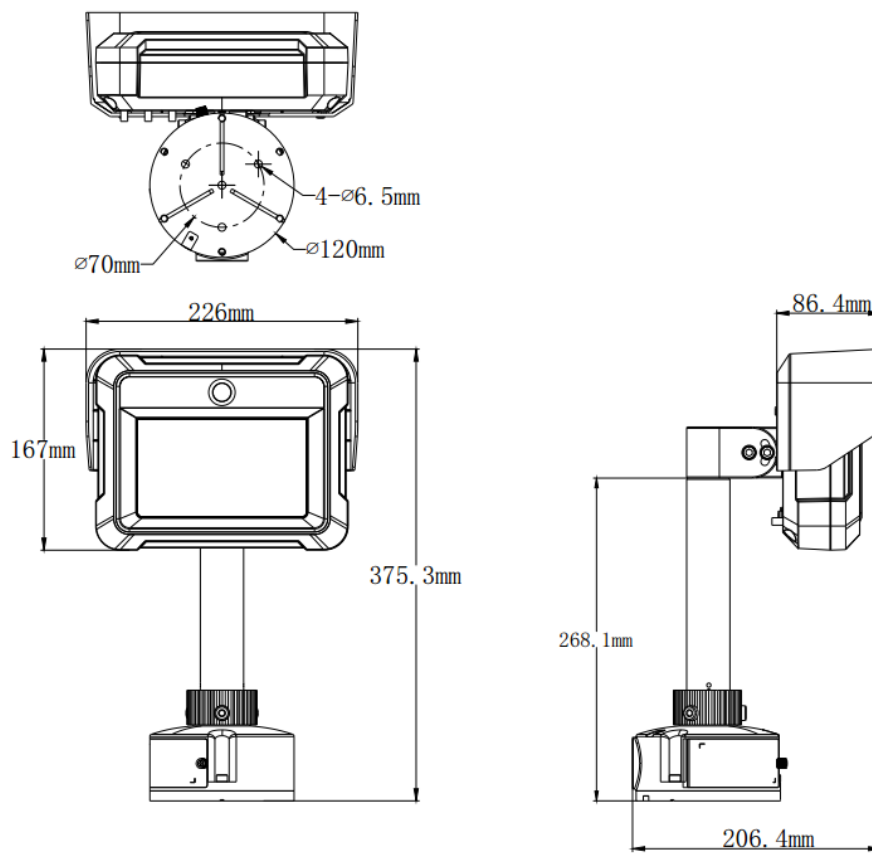

Distributed by

**HIKVISION®****Headquarters**

No.555 Qianmo Road, Binjiang District,
Hangzhou 310051, China
T +86-571-8807-5998
overseasbusiness@hikvision.com

Hikvision USA
T +1-909-895-0400
sales.usa@hikvision.com

Hikvision Australia
T +61-2-8599-4233
salesau@hikvision.com

Hikvision India
T +91-22-28469900
sales@pramahikvision.com

Hikvision Canada
T +1-866-200-6690
sales.canada@hikvision.com

Hikvision Thailand
T +662-275-9949
sales.thailand@hikvision.com

Hikvision Europe
T +31-23-5542770
sales.eu@hikvision.com

Hikvision Italy
T +39-0438-6902
info.it@hikvision.com

Hikvision Brazil
T +55 11 3318-0050
Latam.support@hikvision.com

Hikvision Turkey
T +90 [216]521 7070- 7074
sales.tr@hikvision.com

Hikvision Malaysia
T +601-7652-2413
sales.my@hikvision.com

Hikvision UK & Ireland
T +01628-902140
sales.uk@hikvision.com

Hikvision South Africa
Tel: +27 (10) 0351172
sale.africa@hikvision.com

Hikvision France
T +33(0)1-85-330-450
info.fr@hikvision.com

Hikvision Kazakhstan
T +7-727-9730667
nikia.panfilov@hikvision.ru

Hikvision Vietnam
T +84-974270888
sales.vt@hikvision.com

Hikvision UAE
T +971-4-4432090
salesme@hikvision.com

Hikvision Singapore
T +65-6684-4718
sg@hikvision.com

Hikvision Spain
T +34-91-737-16-55
info.es@hikvision.com

Hikvision Tashkent
T +99-87-1238-9438
uzb@hikvision.ru

Hikvision Hong Kong
T +852-2151-1761
info.hk@hikvision.com

Hikvision Russia
T +7-495-669-67-99
saleru@hikvision.com

Hikvision Korea
T +82-(0)31-731-8817
sales.korea@hikvision.com

Hikvision Poland
T +48-22-460-01-50
info.pl@hikvision.com

Hikvision Indonesia
T +62-21-2933759
Sales.Indonesia@hikvision.com

Hikvision Colombia
sales.colombia@hikvision.com