

//DATASHEET

SALTO Locks | AElement

Access control requires a good, reliable door locking system. SALTO offers a wide range of mortise locks in order to ensure that the door is correctly locked.

Whether you need ANSI mortise locks, Euro locks for wooden doors or narrow profiles, DIN locks, Scandinavian standard locks, cylindrical cartridge latches or automatic locks with privacy and panic functions, **SALTO has the locking system you need.**

MORTISE LOCKS **LA1Tx7**

SALTO
inspired**access**



SALTO LOCKS TUBULAR LATCH

The XS4 ANSI mortise lock is specially designed for doors that need an ANSI mortise lock ANSI in line with an A 156.13 Grade 1 mortise lock.

This lock is easy to install, provides security and is robust.

MODEL LA1T17

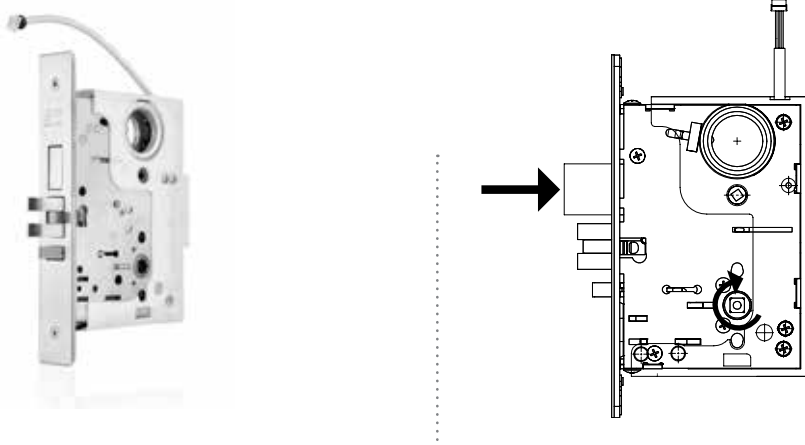

MAIN CHARACTERISTICS:

- Latch operation on levers on both sides
- External handle blocking
- Lever retracts deadbolt and latch simultaneously
- Auxiliary latch (anticard) deadlocks latch and deadbolt
- Reversible latch and blocking
- Handle and privacy detector
- Door and override detector (depending on the model)
- Override retracts latch and deadbolt
- Stainless steel with anti-friction latch 3/4" throw

MODEL LA1T07

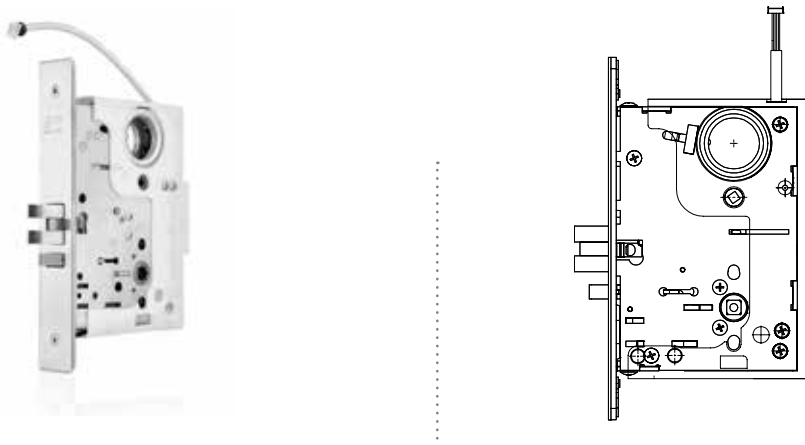

MAIN CHARACTERISTICS:

- Latch operation on levers on both sides
- External handle blocking
- Auxiliary latch deadlocks latch
- Reversible latch and blocking
- Handle and privacy detector
- Door and override detector (depending on the model)
- Override retracts latch

MECHANICAL FEATURES

- Lock case made of stamped steel
- Finishes available: Satin Stainless Steel or Polished Brass
- Faceplate: adjustable level
- 8mm (5/16") square split spindle
- Strike: reversible
- Latch: reversible
- Fire resistant UL Listed 90 mins
- In line with ANSI/BHMA A 156.13 Grade 1 compliant for heavy commercial, institutional and industrial use

ANSI MORTISE LOCK WITH DEADBOLT

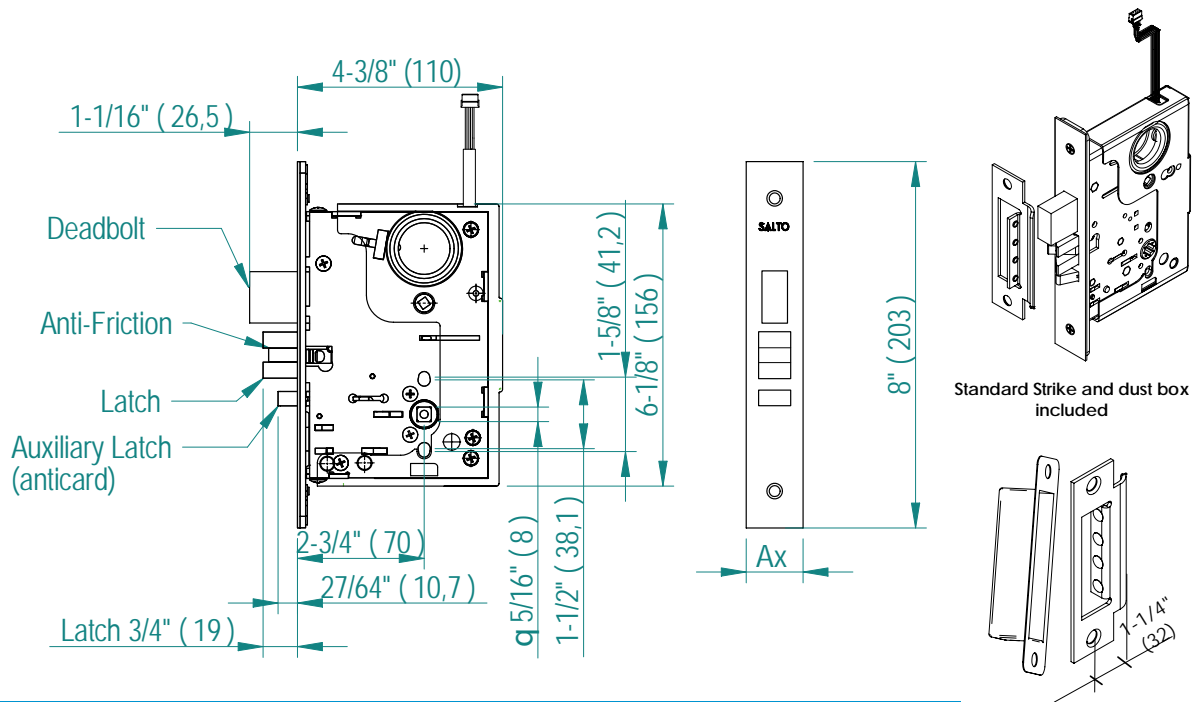

ANSI MORTISE LOCK (NO DEADBOLT)

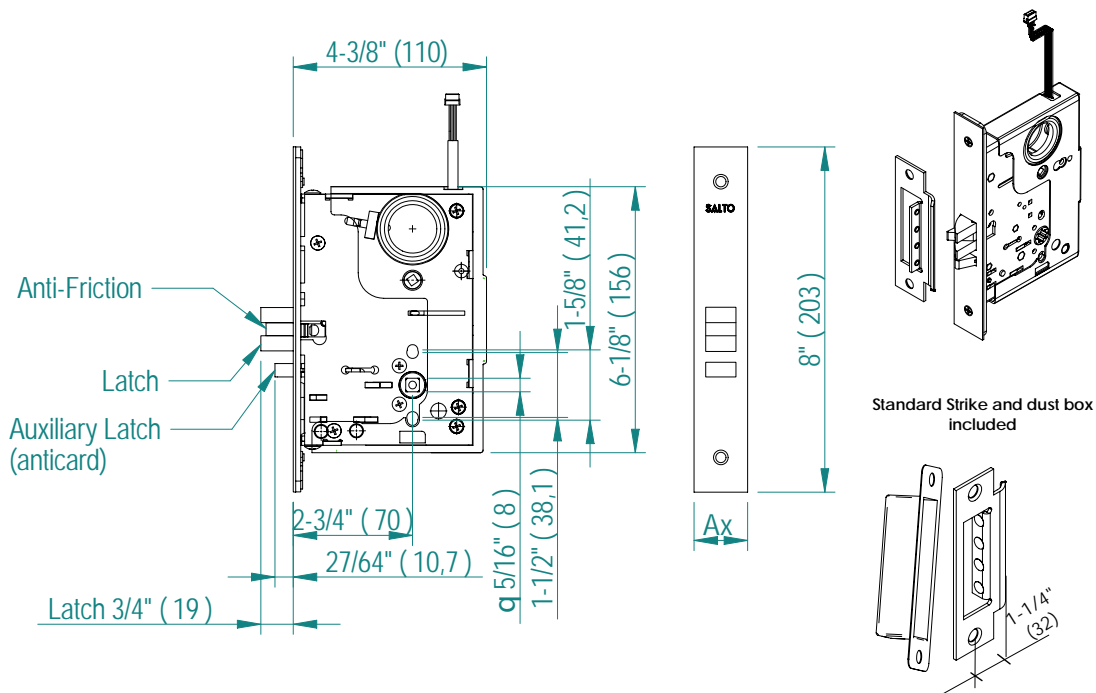

HANDING CODE

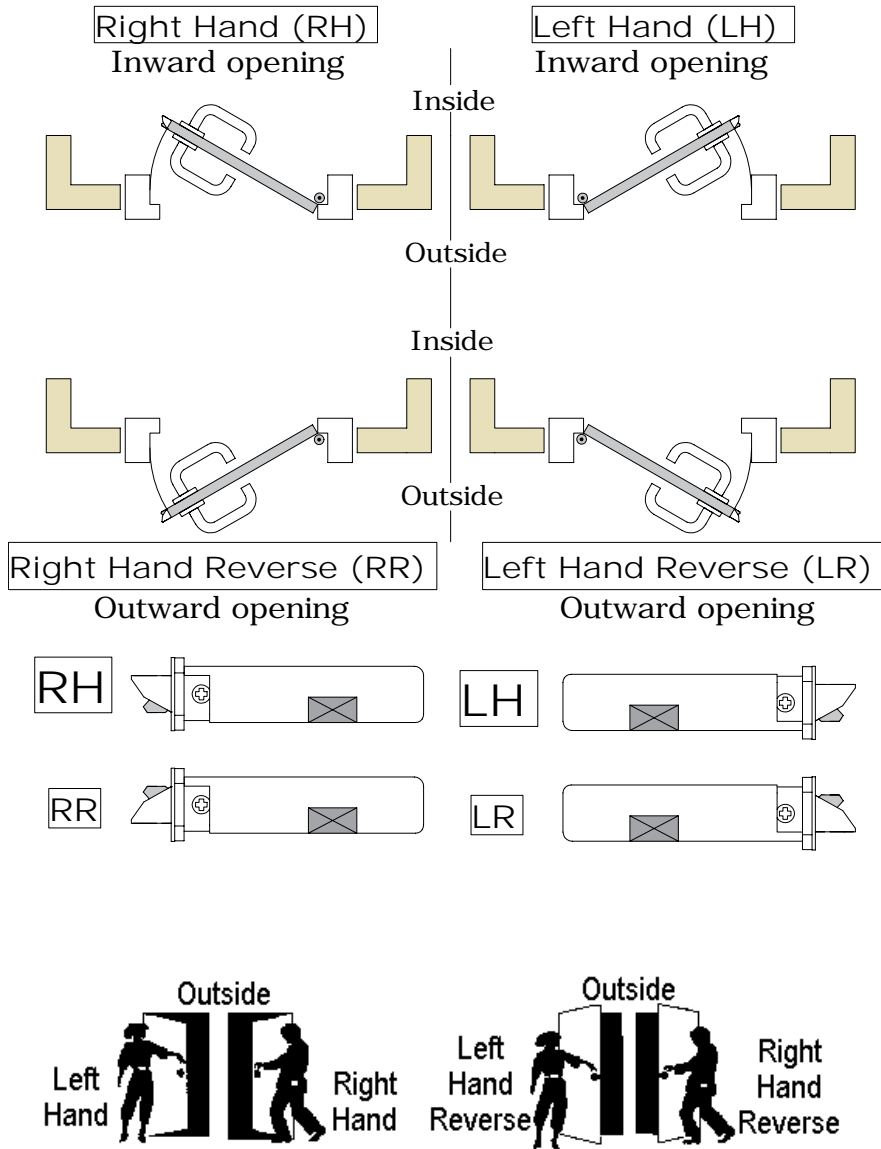

LATCHBOLT POSITION CHANGE

LATCHBOLT POSITION CHANGING

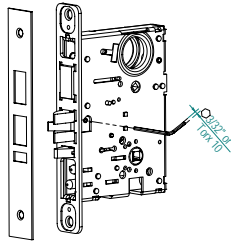

1. Remove special screw with allen wrench

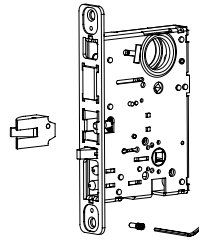

2. Pull latch bolt out of lock

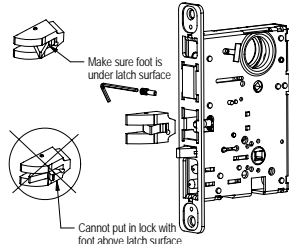

3. Rotate latch bolt 180° and reinstall into lock, pushing the latch bolt into the lock and then releasing

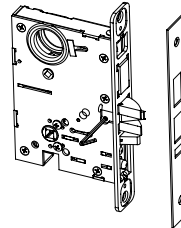

4. From opposite side, insert the special screw and tighten securely with the allen wrench.

LOCKING SLIDE POSITION CHANGE

LOCKING SLIDE POSITION CHANGING

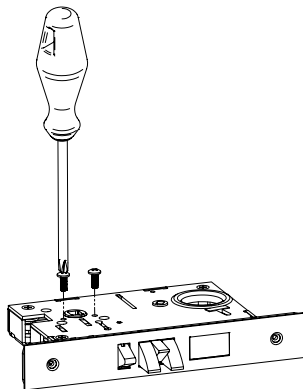

1. Remove 2 screws as shown above

Dimension in inches (dimension in millimetres)

All contents current at time of publication.
SALTO Systems S.L. reserves the right to change availability of any item in this catalogue, its design, construction, and/or materials.

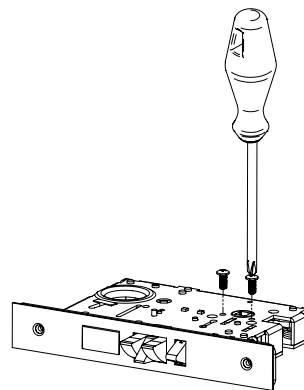

2. Turn lock over opposite side and reinstall screws as shown above. To ensure locking slide does not bind, manually push to the desired side or alternate tightening each screw every 2-3 turns.

LOCK INSTALLATION

PREPARING THE DOOR

1. Draw a horizontal line on edge of the door and on inside at the desired height of knob above floor.
2. Draw a vertical centre line on door edge.
3. Draw a vertical line on inside at the proper backset to align the template.
4. Position template on edge of door. Mark ONLY top and bottom holes of mortise cavity (A) and lock front on door edge. Remove template: Place lock face against door edge. Trace outline of faceplate as guide for faceplate routing.
5. Mortise door for lock body and faceplate as per instructions on template.
6. Position template on inside of door. Mark holes in the lateral face of the door for turnpiece (B) and handles (C and D). Mark the corresponding holes for the electronic escutcheon fixings (E and F). The (F) hole doesn't have to be through, its depth has to be $\frac{3}{4}$ " longer than the lock center.

INSTALLING THE LOCK BODY

1. Insert wires through (F) hole.
2. Insert the lock into the cavity.
3. Mark & drill faceplate holes.
Fasten with faceplate screws to hold lock in place.

INSTALLING THE STRIKE

1. Center strike to lock's frontplate center lane. Refer to latch to determine strike location on jamb.
2. Using strike as template, mark and chisel recess.
Drill holes for dust box. Place dust box and strike and fasten screws.
Please check that:
 - Deadbolt and latch fit the cavities of the strike without touching it.
 - Gap between door and jamb is $\frac{1}{8}$ ".

