

Product description

The product is equipped with an electric motor and opens single action doors and swing doors. It is suitable for horizontal or vertical installation in the door frame or door leaf.

The door contact and the armature contact are designed as free switching contacts. The door contact is activated magnetically when the door is closed. The armature contact can be used to monitor the lock status.

The product is fail-safe and is suitable for escape doors. In the event of power loss or if the power fails, the bolt can be pushed back.

Overview of Advantages

- Very quiet locking and unlocking, silent during permanent release
- Suitable for double-action swing doors and single-action swing doors, interlocking doors and special doors
- Vertical and horizontal universal installation position in the door frame or in the door leaf
- Holding force of 510 kg
- Safe unlocking under pre-load of up to 510 kg
- 12V DC to 24V DC multi-voltage, controlled DC
- Voltage Monitoring contact and armature contact integrated
- Compatible with 351 Solenoid

Technical data

Input Operating Voltage	12VDC ± 10%; 24VDC ± 10%
Operating Current	880mA @ 12VDC; 520mA @ 24VDC
Holding Current	480mA @ 12VDC; 270mA @ 24VDC
Pre-Load	510kg
Holding Force	510kg
Handing	Universal
Installation	Vertical or Horizontal
Monitoring contact	Yes
Fail Safe (Power-To-Lock)	Yes
Finish	Stainless Steel
Bolt material	Steel
Bolt length	10mm
Operating Temperature Range	-15 °C to +50 °C
Length	200mm
Width	25mm
Depth	42mm
Rebate gap	3mm

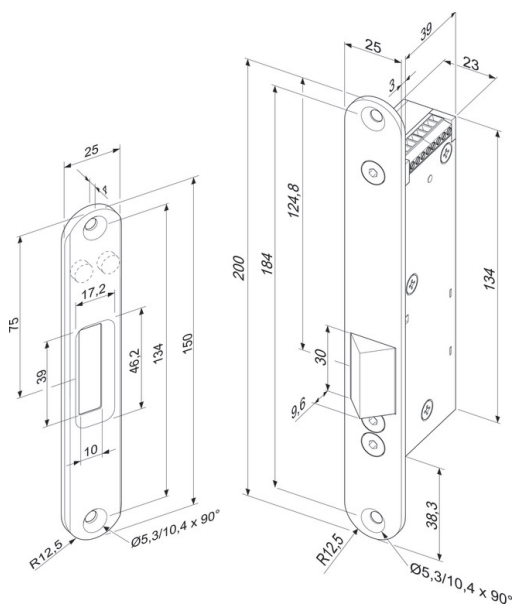

For more information please see your ASSA ABLOY representative.