

**OpenEye**<sup>®</sup>  
The Cloud Video Platform

**MD – SERIES GEN 2  
CLOUD MANAGED  
APPLIANCE**

USER MANUAL

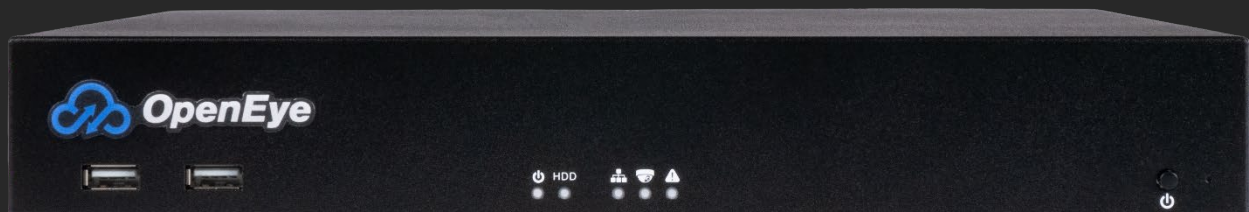

OpenEye MD-Series Gen 2 Cloud-Managed Appliance  
User Manual

Manual Edition 37876AE – July 2023

©2023, OPENEYE  
All Rights Reserved

No part of this document may be reproduced by any means, electronic or mechanical, for any purpose, except as expressed in the Software License Agreement. OPENEYE shall not be liable for technical or editorial errors or omissions contained herein. The information in this document is subject to change without notice.

The information in this publication is provided “as is” without warranty of any kind. The entire risk arising out of the use of this information remains with recipient. In no event shall OPENEYE be liable for any direct, consequential, incidental, special, punitive, or other damages whatsoever (including without limitation, damages for loss of business profits, business interruption or loss of business information), even if OPENEYE has been advised of the possibility of such damages or whether in an action, contract or tort, including negligence.

This documentation is copyrighted. All other rights are reserved to OPENEYE. Heroic Customer Service, OpenEye Web Services are registered trademarks of OPENEYE in the United States and elsewhere; Windows is a registered trademarks of Microsoft Corporation. All other brand and product names are trademarks or registered trademarks of the respective owners.

The following words and symbols mark special messages throughout this guide:



**Note** Text set off in this manner indicates information that is necessary for proper operation of the product.

## IMPORTANT SAFEGUARDS

---

1. **Read the Hardware Manual** – After unpacking this product, read the owner's manual carefully, and follow all the operating and other instructions.
2. **Power Sources** – This product should be operated only from the type of power source indicated on the label. If not sure of the type of power supply to your home or business, consult product dealer or local power company.
3. **Ventilation** – Slots and openings in the chassis are provided for ventilation and to ensure reliable operation of the product and to protect it from overheating, and these openings must not be blocked or covered. The product should not be placed in a built-in installation such as a bookcase or rack unless proper ventilation is provided or OpenEye's instructions have been adhered to.
4. **Heat** – The product should be situated away from heat sources such as radiators, heat registers, stoves, or other products that produce heat.
5. **Water and Moisture** – Do not use this product near water.
6. **Power Cord Protection** – Power-supply cords should not be routed so that they are likely to be walked on or pinched by items placed against them, paying particular attention to cords at plugs, receptacles, and the point where they exit the product.
7. **Overloading** – Do not overload wall outlets; extension cords, or integral convenience receptacles as this can result in a risk of fire or electrical shock.
8. **Object and Liquid Entry Points** – Never insert foreign objects into the recorder, other than the media types approved by OpenEye, as they may touch dangerous voltage points or short-out parts that could result in a fire or electrical shock. Never spill liquid of any kind on the product.
9. **Installation Surface** – Do not place this product on an unstable cart, stand, tripod, bracket, or table. The product may fall, causing serious personal injury and serious damage to the product.
10. **Burden** – Do not place a heavy object on or step on the product. The object may fall, causing serious personal injury and serious damage to the product.
11. **Replaceable Batteries** – CAUTION: Risk of Explosion if Battery is replaced by an Incorrect Type. Dispose of Used Batteries According to the Instructions.
12. **Grounded Outlet** – This equipment shall be connected to a properly grounded outlet.
13. **Outlet Location** – This equipment must be installed within six feet of an easily accessible outlet.
14. **Damage Requiring Service** – Unplug the unit from the outlet and refer servicing to qualified service personnel under the following conditions:
  - When the power-supply cord or plug is damaged.
  - If liquid has been spilled, or objects have fallen into the unit.

- If the unit has been exposed to rain or water.
  - If the unit does not operate normally by following the operating instructions. Adjust only those controls that are covered by the operating instructions as an improper adjustment of other controls may result in damage and will often require extensive work by a qualified technician to restore the unit to its normal operation
  - If the unit has been dropped or the enclosure has been damaged.
  - When the unit exhibits a distinct change in performance - this indicates a need for service.
15. **Servicing** – Do not attempt to service this product. Opening or removing covers may expose the user to dangerous voltage or other hazards. Refer all servicing to qualified personnel.
16. **Replacement Parts** – When replacement parts are required, be sure the service technician has used replacement parts specified by OpenEye or have the same characteristics as the original part. Unauthorized substitutions may result in fire, electric shock or other hazards.
17. **Safety Check** – Upon completion of any service or repairs to this unit, ask the service technician to perform safety checks to determine that the unit is in proper operating condition.

---

## NOTES ON HANDLING

---

Please retain the original shipping carton and/or packing materials supplied with this product. To ensure the integrity of this product when shipping or moving, repackage the unit as it was originally received from OpenEye.

Do not use volatile liquids, such as aerosol spray, near this product. Do not leave rubber or plastic objects in contact with this product for long periods of time. They will leave marks on the finish.

The top and rear panels of the unit may become warm after long periods of use. This is not a malfunction.

---

## FCC STATEMENT

---

This equipment has been tested and found to comply with the limits for a Class A digital device, pursuant to Part 15 of the FCC Rules. These limits are designed to provide reasonable protection against harmful interference when the equipment is operated in a commercial environment. This equipment generates, uses, and can radiate radio frequency energy and, if not installed and used in accordance with the instruction manual, may cause harmful interference to radio communications. Operation of this equipment in a residential area is likely to cause harmful interference in which case the user will be required to correct the interference at his own expense.

---

## EN 55022 Class A Notice

---

### WARNING

This is a class A product. In a domestic environment this product may cause radio interference in which case the user may be required to take adequate measures.

---

## WARNING

---

TO REDUCE THE RISK OF ELECTRICAL SHOCK, DO NOT EXPOSE THIS APPLIANCE TO RAIN OR MOISTURE.

DANGEROUS HIGH VOLTAGES ARE PRESENT INSIDE THE ENCLOSURE.

DO NOT OPEN THE CABINET.

REFER SERVICING TO QUALIFIED PERSONNEL ONLY.

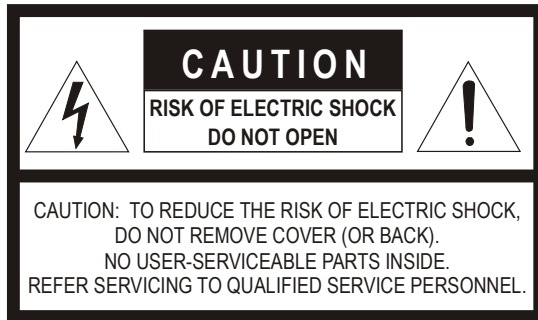

---

## AVERTISSEMENT

---

POUR RÉDUIRE LE RISQUE DE CHOC ÉLECTRIQUE, N'EXPOSEZ PAS CET APPAREIL À LA PLUIE OU À L'HUMIDITÉ.

DES TENSIONS ÉLEVÉES DANGEREUSES SONT PRÉSENTES À L'INTÉRIEUR DE L'ENCEINTE.

N'OUVREZ PAS L'ARMOIRE.

RÉFÉRER L'ENTRETIEN AU PERSONNEL QUALIFIÉ SEULEMENT.



---

## EXPLANATION OF GRAPHICAL SYMBOLS

---



The lightning flash with arrowhead symbol, within an equilateral triangle, is intended to alert the user to the presence of un-insulated "dangerous voltage" within the product enclosure that may be of sufficient magnitude to constitute a risk of electric shock to persons.

---

## EXPLICATION DES SYMBOLES GRAPHIQUES

---



L'éclair avec le symbole de la pointe de flèche, à l'intérieur d'un triangle équilatéral, est destiné à alerter l'utilisateur de la présence d'une « tension dangereuse » non isolée dans l'enceinte du produit qui peut être d'une ampleur suffisante pour constituer un risque de choc électrique pour les personnes.

---

## Standard Warranty

---

OpenEye warrants all new products, purchased through authorized OpenEye resellers & Distributors, to be free from defects in workmanship and material under normal use for a **period of two years** after the date of purchase. Any defective product that falls under this warranty will, at OpenEye's discretion, be repaired or replaced at no additional charge. OpenEye may elect to replace defective products with new or factory reconditioned products of equal or greater value. Repairs made necessary by reason of misuse, alteration, normal wear, or accident are not covered under this warranty.

Exceptions to this are listed below:

Three Years on all Digital Recorders

Three years on all analog and IP fixed cameras

All products shall be covered by a one-year advance replacement warranty\*.

OpenEye will warrant all otherwise out of warranty replacement parts and repairs for 90 days from the date of OpenEye shipment.

The above warranty is the sole warranty made by OpenEye and is in lieu of all other warranties by OpenEye express and implied, including without limitation the warranties of merchantability and fitness for a particular purpose. Under no circumstances will OpenEye be liable for any consequential, incidental, special or exemplary damages arising out of or connected with the sale, delivery, use or performance of the product, even if OpenEye is apprised of the likelihood of such damages occurring. In no event shall OpenEye liability exceed the purchase price of the product.

This warranty gives you specific legal rights and you may also have other rights which vary from state to state or country to country.

This warranty does not apply to products purchased through unauthorized sales channels.

*\*Requires corresponding security deposit. Advanced Replacement limited to components only outside of the USA and Canada.*

28574AJ

For the most up to date information visit [www.openeye.net](http://www.openeye.net).

# TABLE OF CONTENTS

TABLE OF CONTENTS.....	8
INTRODUCTION .....	9
Product Description.....	9
Features .....	10
Controls and Connections .....	11
MD-Series Front Panel (8 Channel) .....	11
MD-Series Rear Panel (8 Channel).....	11
MD-Series Front Panel (16 Channel).....	12
MD-Series Rear Panel (16 Channel).....	12
Getting Started.....	13
Box Contents.....	13
Mouse Setup.....	14
Monitor Setup .....	15
Connecting a Camera Using a PoE Port .....	15
Setting Up the Recorder for the First Time .....	16
Default Username & Password .....	16
Connecting to OpenEye Web Services .....	16
OPERATING THE RECORDER .....	17
Turning On the Recorder .....	17
Turning Off the Recorder .....	17
System Recovery .....	17



# INTRODUCTION

## PRODUCT DESCRIPTION

---



The OpenEye MD-Series (OE-MD) appliance is designed to offer customers a cost-effective IP recording solution. The all metal, compact 1U chassis is well suited for installation in a variety of environments. Available with a built-in 8 or 16 channel PoE switch, the MD-Series cloud-managed appliance features dual network ports and runs a secure Linux Operating System. A solid-state OS hard drive comes standard to improve reliability and provide faster boot times.

The MD-Series cloud-managed appliance is fully integrated with OpenEye Web Services and offers centralized user management, single sign-on convenience, mobile apps and a web client that allows for easy remote connection to your recorders. Complete network setup is hassle free thanks to OpenEye's Web Connect technology which eliminates the need for port forwarding or entering IP settings into remote clients.

To learn more about the MD-Series recorder or the rest of OpenEye's M-Series recorder lineup visit [openeye.net](http://openeye.net).

## FEATURES

---

OpenEye's MD-Series recorders include the following features:

- Complete remote operation and administration with Web Connect
- Record up to 24 channels of IP video per appliance
- 8 and 16 channel on-board PoE
- Up to 24TB on-board storage
- Dual GbE for Dedicated Client and Camera Networks
- Desktop Form Factor with rack mount capability (16CH only)
- Dedicated OS SSD

## CONTROLS AND CONNECTIONS

### MD-SERIES FRONT PANEL (8 CHANNEL)

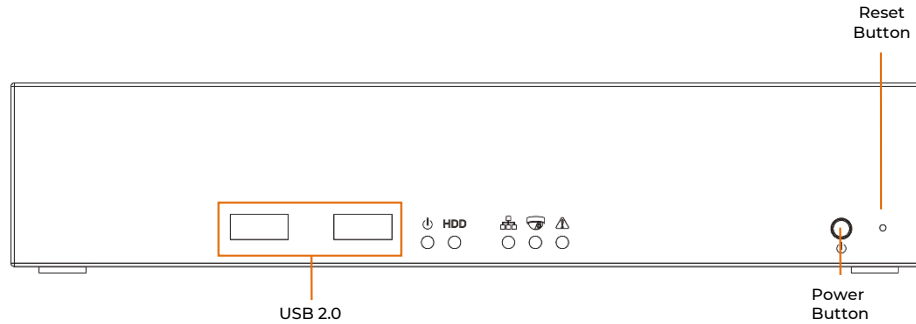

### MD-SERIES REAR PANEL (8 CHANNEL)

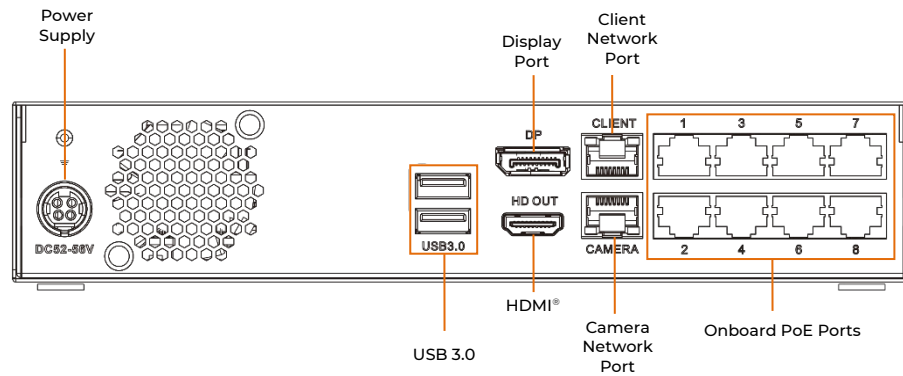

**WARNING** The Camera Network Port is equipped with a DHCP server and intended for use only with a dedicated independent camera network on its own network switch. Connecting the Camera Port to a network with another DHCP server will cause significant network issues.

## MD-SERIES FRONT PANEL (16 CHANNEL)

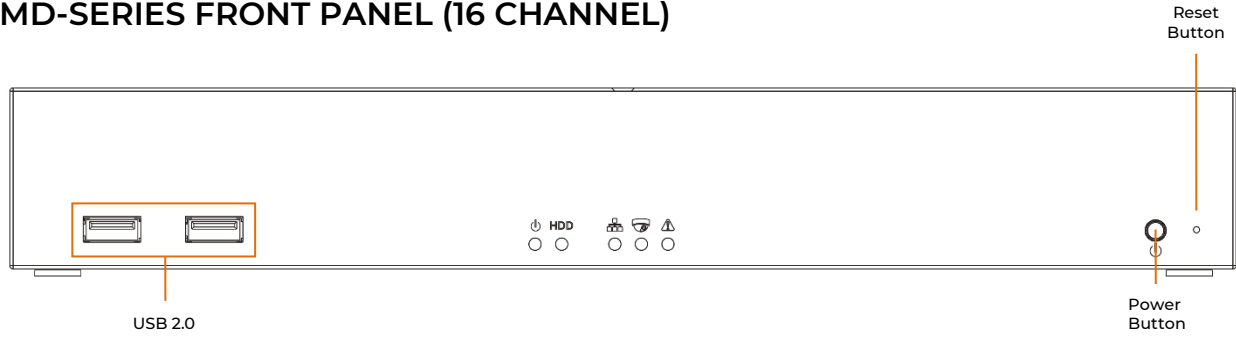

## MD-SERIES REAR PANEL (16 CHANNEL)

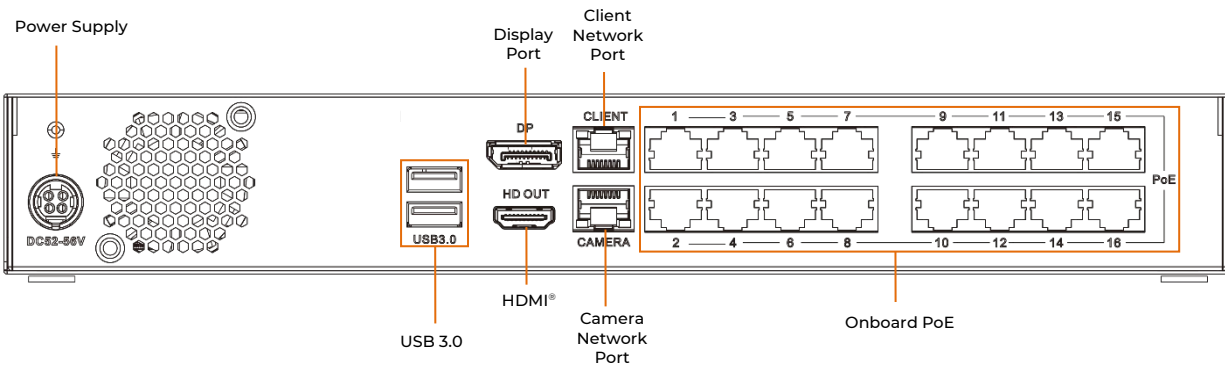



**WARNING** The Camera Network Port is equipped with a DHCP server and intended for use only with a dedicated independent camera network on its own network switch. Connecting the Camera Port to a network with another DHCP server will cause significant network issues.

## GETTING STARTED

---

### BOX CONTENTS

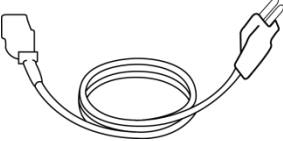
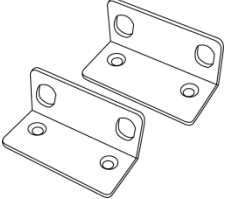
OpenEye's MD-Series recorders come with a power cord, mouse, and a rack mount or wall mount installation kit. Identify the following components to make sure everything has been properly included with the new recorder. If any of the following items are missing, contact the dealer to arrange a replacement.

 <p>OE-MD Series Recorder</p>	 <p>Power Cord</p>
 <p>Rack Mount or Wall Mount Installation Kit</p>	 <p>Mouse</p>

## MOUSE SETUP

---

To attach the mouse to your recorder, connect the mouse to a USB port located on the back of the machine.

In this manual:

**Click** means to position the mouse cursor over an item and to single click the left button.

**Right click** means to position the mouse cursor over an item and to single click the right button.

**Double-click** means to position the mouse cursor over an item and to click the left button twice.

**Select** means to position the mouse cursor over a radio button, checkbox, or list item and click on it.

The scroll wheel in between the two buttons is used for added navigation functionality. By moving the wheel with index finger (scrolling), quickly move through multiple pages, lines, or windows. The wheel may also function as a third button allowing the user to quickly click or double-click an icon or a selected item.

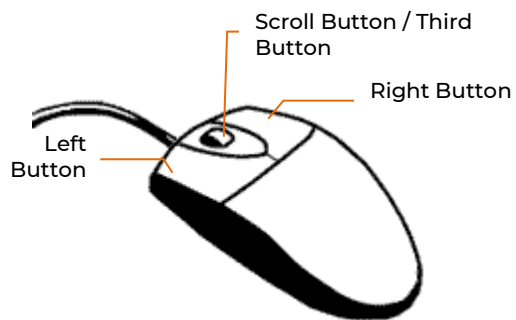

## MONITOR SETUP

An HD Out connection is available to connect a monitor:



HDMI Output



Display Port

Attach the monitor(s) to the rear of the recorder using the cable supplied by the monitor manufacturer. Refer to the monitor manual for detailed information on how to setup and use it.



**Note** In some instances, the HDMI® port will not initialize the monitor to display the BIOS. Using the DisplayPort output will resolve this issue.



**Note** The monitor must be capable of a minimum screen resolution of 1024x768 and support 32 bit color.

## CONNECTING A CAMERA USING A POE PORT

---

The MD-Series recorder is equipped with an on-board Power over Ethernet (PoE) switch for use with PoE IP cameras. Connect one end of the camera and the other end of the cable to the network switch or recorder.

## SETTING UP THE RECORDER FOR THE FIRST TIME

---

1. Connect the network cable intended for remote connections to the **Client Network Port**.



**Note** The Camera Network Port is intended for use with a dedicated camera network.

2. Connect the supplied **mouse** using the USB ports.
3. Connect a **monitor** using the HDMI® or Display Port.



**Note** The recorder may take up to 30 seconds to initialize the display.

4. Connect the cameras to PoE ports, or the external camera network.

**WARNING** The Camera Network Port is equipped with a DHCP server and intended for use only with a dedicated independent camera network on its own network switch. Connecting the Camera Port to a network with another DHCP server will cause significant network issues.

5. Plug the supplied **power cord** into the recorder and connect it to a power source.

## DEFAULT USERNAME & PASSWORD

---

### APEX LOGIN:

Log in to the Apex Server recorder using the default credentials:

**Username:** admin

**Password:** 1234

Complete the **First Time Wizard** for basic system setup.

## CONNECTING TO OPENEYE WEB SERVICES

---

1. On the Apex appliance, click **Setup** and then navigate to the **Remote Services** tab.
2. Click **Web Services**.
3. Type the **Recorder Registration Code**.
4. Click **Connect**.



# OPERATING THE RECORDER

## TURNING ON THE RECORDER

---

1. Press the power button on the front of the recorder.
2. The recorder will run a series of self-tests. If asked to respond to any messages, follow the instructions carefully.

## TURNING OFF THE RECORDER

---

3. Go to **Setup** and select **Power Options**.
4. Click **Power Off**.

## SYSTEM RECOVERY

---

### [System Recovery Instructions](#)



**Note** Call OpenEye Support at 888-542-1103, option #2, for more information regarding the recovery process.

openeye.net

888-542-1103

© 2023 OpenEye

All rights reserved. No part of this publication may be reproduced by any means without written permission from OpenEye. The information in this publication is believed to be accurate in all respects. However, OpenEye cannot assume responsibility for any consequences resulting from the use thereof. The information contained herein is subject to change without notice. Revisions or new editions to this publication may be issued to incorporate such changes.