

KS200 (Wiegand) & KS210 (OSDP) Integrated Wired Server Cabinet Lock



ASSA ABLOY

Experience a safer
and more open world

Installation & Operating Instructions

Operation

To activate the KS200/KS210 integrated electronic access control Server Cabinet Lock, present a known/valid credential to the card reader. For emergency override, insert a valid key in to the SFIC (Small Format Interchangeable Core) cylinder and rotate to the unlocked position. Upon access granted, verify functionality by lifting and rotating the handle to release the locking cam and open the door.

NOTE: The unit shall be powered by a UL294 listed power supply or access control output with a power limited Class 2 output. The DC input feed to the device shall be protected by 1A max rated over current protection provided at the installation site.

ASSA ABLOY recommends the use of Securitron and Life Safety Power power management products for use with ASSA ABLOY branded electromechanical and integrated electronic access control locking devices.

Product Contents

- | | |
|--|---|
| A KS200/KS210 Lock Body | G Screw (1) #1/4-20 x 1/2"
Truss Head Phillips |
| B Lock Interface Cable | H SFIC Cam & Spacer |
| C Rear Mounting Bracket | I Plug-In External DPS Adapter
(Optional) |
| D Connectors (3) | |
| E Screws (3) #8/32 x 1/4"
Pan Head Phillips | |
| F Locking Cam | |

Diagram 1: Product Components

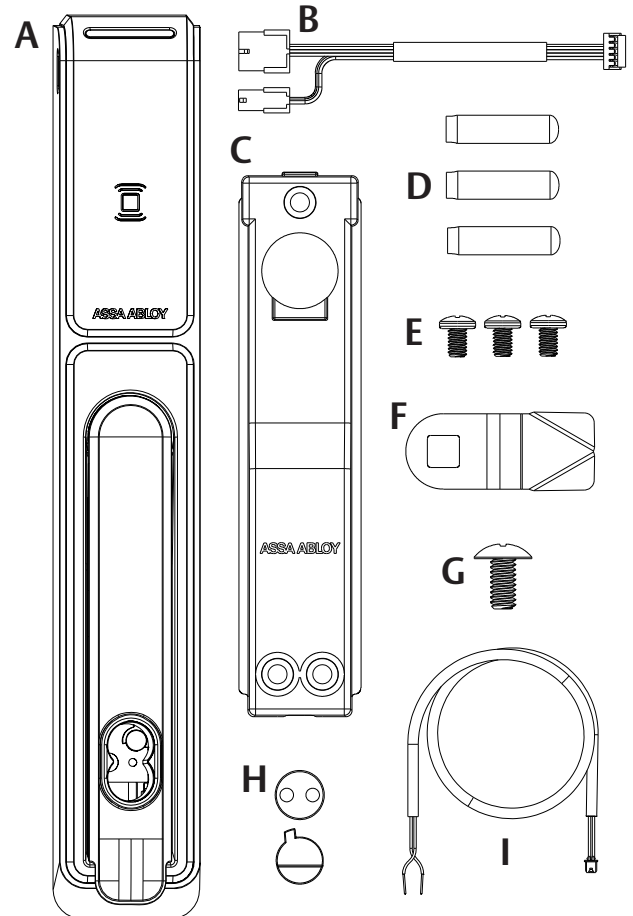

Recommended Tools

- Phillips #2 Screwdriver
- Cutting Wheel (As Required)

Recommended Accessories

- **SFIC** Mechanical Core and Keys
- **KS-DPS** Door Open/Closed Status
- **CBL6-QC12** 6 ft Door Interface Cable
- **CBL12-QC12** 12 ft System Side Interface Cable
- **WT-2** Securitron Wiegand Test Box



KS200

- **Contains FCC ID:** JQ6-ICLASSBTM
- **Contains IC ID:** 2236B-ICLASSBTM
- **WPC ID:** ETA-SD-20210402373

KS210

- **FCC ID:** VC3-KS210
- **IC ID:** 7160A-KS210
- **WPC ID:** ETA-SD-20210402371

WARNING: This product can expose you to chemicals including lead, which is known to the state of California to cause cancer and birth defects or other reproductive harm. For more information go to P65Warnings.ca.gov.

Specifications

Designed For Use With Data Server Cabinets (9U or larger).

- **Lock Prep** 150 x 25 mm
- **Locking Type** Cam Activated
- **Mechanical Key Override** SFIC 6 or 7-Pin (Sold Separately)
- **Holding Force** 350 lbs

Electrical

- **Communication** KS200 (Wiegand TTL, SIAAC-01-1996) KS210 (OSDP RS-485, SIA v2.2, IEC 60839-11-5)
- **Card Technology** HID multiCLASS SE
- **HID Mobile Access** NFC or BLE
- **LED Visual Indicator** Red / Green / Amber
- **Voltage** 12 to 24 VDC (-10% to +15% per UL294)

Environmental

- 32° to 122°F [-10° to 50°C]
- **Weather Resistance** Tested to meet IP54 (Not evaluated by UL)
- Indoor Use Only

Current Consumption

INPUT VOLTAGE	12 V DC	24 V DC
Standby Avg¹	50 mA	40 mA
Max Avg²	100 mA	75 mA
Peak³	130 mA	130 mA

1 Standby AVG – RMS current draw without a card in the RF field with both LEDs active.

2 Maximum AVG – RMS current draw during continuous card reads, and both LEDs active.

3 Peak – Highest instantaneous current draw during RF Communication, in-rush, or unlock cycles.

Certification & Listings

- **UL294 Performance Levels**
 - **Destructive Attack** Level 1 (Attack Test)
 - **Line Security** Level 1* (Line Security)
 - **Endurance** Level 4 (250,000 Cycles)
 - **Standby Power** Level 1* (No Standby)

*NOTE: Line Security, Destructive Attack and Standby Power are determined by the end-product application.

Hereby, Hanchett Entry Systems, Inc (HES) declares that the radio equipment type KS200/ KS210 are in compliance with Directive 2014/53/ EU. The full text of the EU declaration of conformity is available at the following internal address:

assaabloyesh.com/en/tech-info/digital-asset-search

Credential Formats Supported

RF Frequency / Power

RADIO	FREQUENCY (MHZ)	MAX OUTPUT POWER (mW)
RFID	0.125	108
RFID	13.56	1375
Bluetooth LE (KS210 Only)	2480	1

LF (125 kHz Low Frequency)

CARD TECHNOLOGY	KS200	KS210
HID Prox	✓	✓
Indala Prox	✓	✓
EM4102	✓	✓
AWID Prox	✓	✓
Kantech Prox		

KS200 (Wiegand) Models

CARD TECHNOLOGY	DESCRIPTION	LF	HF	BLE
IPS	Standard	✓	✓	
IPE-XXXXX	HID iCLASS Elite		✓	
PIV040	PIV 40-bit		✓	
PIV064	PIV 64-bit		✓	
PIV075	PIV 75-bit		✓	
PIV128	PIV 128-bit		✓	
PIV200	PIV 200-bit		✓	

HF (13.56 MHz High Frequency)

CARD TECHNOLOGY	KS200	KS210
ISO 14443 A/B	✓	✓
ISO 15693 – Felica™ (IDm)	✓	✓
HID iCLASS® Standard	✓	✓
HID iCLASS® Elite*	✓	✓
HID iCLASS® SE	✓	✓
HID iCLASS® SR	✓	✓
HID iCLASS® Seos	✓	✓
HID Security Identity Object (SIO)	✓	✓
PIV-II	✓	✓
MIFARE DESFire® 0.6	✓	✓
MIFARE DESFire® EV1	✓	✓
MIFARE DESFire® EV2		

*NOTE: Contact Technical Support at (800) 626-7590 for questions regarding enabling HID iCLASS Elite, BLE** or NFC over HCE.

**The product employs provisions to be used with a mobile credential that utilizes a smart application that is installed on a smart device such as a phone. The mobile credential utilized is required to run on a smart device that employs a compatible operating system:

Apple iOS 11.0 or higher

Android v8.0 or higher

Furthermore, the reader utilizes the Smart devices Bluetooth functions. The units were verified with Bluetooth version 4.2 or higher as well as HID Mobile Access App (Version 3.76) or higher was verified as an access control credential.

KS210 (OSDP) Models

CARD TECHNOLOGY	DESCRIPTION	LF	HF	BLE
IPS	Standard	✓	✓	✓
IPE-XXXXX	HID iCLASS Elite		✓	✓
PIV040	PIV 40-bit		✓	✓
PIV064	PIV 64-bit		✓	✓
PIV075	PIV 75-bit		✓	✓
PIV128	PIV 128-bit		✓	✓
PIV200	PIV 200-bit		✓	✓

Mobile Access*

CARD TECHNOLOGY	KS200	KS210
HID NFC Mobile Access over HCE**	✓	✓
HID BLE Mobile Access**		✓

Mounting

1. LOCATE the 6" x 1" [150 x 25 mm] lock cutout on the door. **Diagram 2.**
2. INSERT the KS200/KS2100 Lock Body (A) into the 6" x 1" [150 x 25 mm] cutout. Make sure the unit bottom tabs grab the back of the wall. **Diagram 3.**
3. ENSURE KS200/KS210 Lock Body (A) is flush against the mounting surface to ensure the tamper switch on the back of the device is fully depressed and operating correctly. **Diagram 4.**
4. CONNECT the female, 10-position Hirose connector on the Lock Interface Cable (B) to the back of the KS200/KS210 Lock Body (A). **Diagram 5.**

- NOTE:** ENSURE that the Lock Interface Cable (B) is not pinched or exposed prior to attaching the Rear Mounting Bracket (C).
- (OPTIONAL) REMOVE the 4-Pin and 8-Pin Molex Connectors from the end of the Lock Interface Cable (B) when the ElectroLynx Interface Cables are NOT utilized.
 - GOTO Optional Quick Connect Guide (CONNECTIONS & WIRING) when using ElectroLynx Interface Cables.

5. (OPTIONAL) CONNECT the Plug-In RS-485 Auxiliary Output Adapter Cable to extend control to other compatible locking devices. **NOTE:** Compatible with KS210 OSDP RS-485 models only.
6. (OPTIONAL) CONNECT the Plug-In External DPS Adaptor (I) **Diagram 6** to extend the Tamper/Locked State Monitoring to include other EXTERNAL normally open switches that can be wired in series to monitor additional doors or panels.

NOTE: The DPS signals a secure state (closed) when the handle is resting in it the locked/latched position.

External DPS/Tamper rated for use up to 100 mA at 30 VDC resistive load.

Diagram 2 Door Preparation

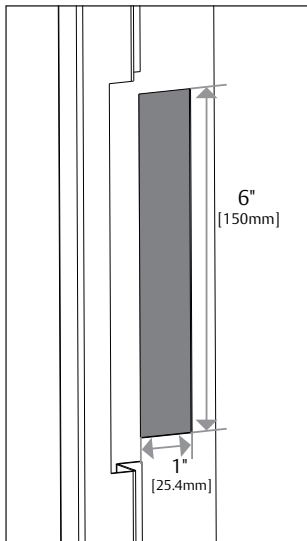

Diagram 3 Insert Lock Body

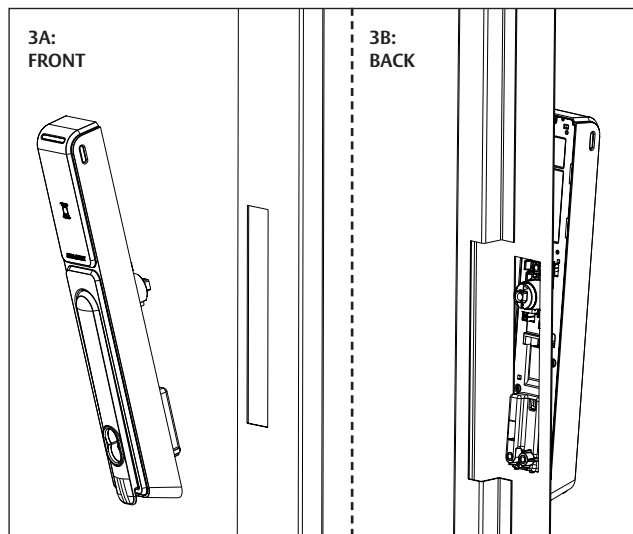

Diagram 4 Tamper Switch

NOTE: If the tamper switch is NOT fully depressed, the Tamper/Locked State/DPS contact will report as a non-secure status.

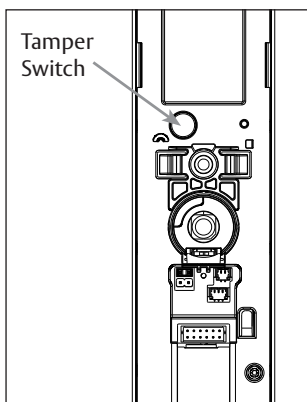

Diagram 5 Connect Lock Interface Cable (B)

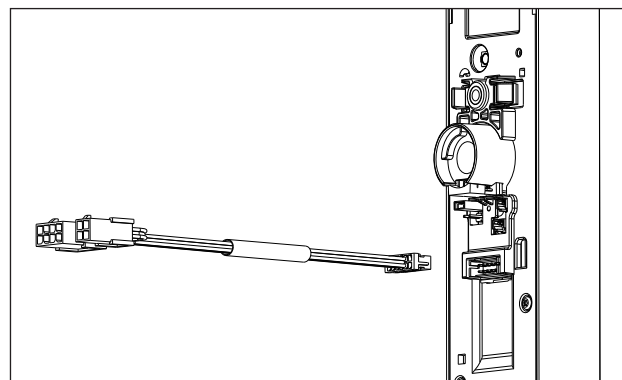
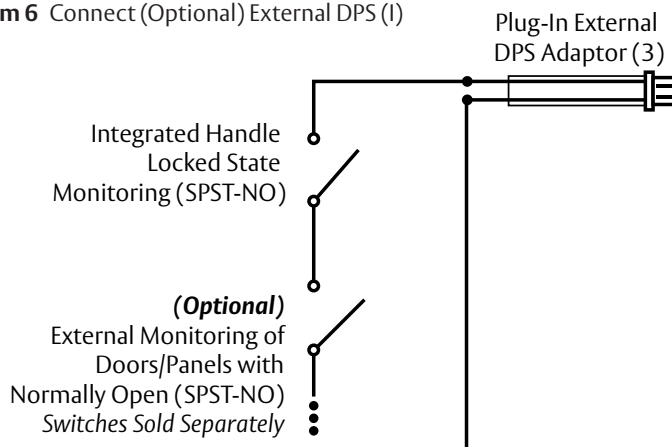

Diagram 6 Connect (Optional) External DPS (I)



7. External DPS Adapter Activation. **Diagram 7.**

- REMOVE the jumper on the back of the KS200/KS210 Lock Body (A).
 - CONNECT the 2-Pin Plug-In External DPS Adapter (I) to the back of the KS200/KS10 Lock Body.
 - CONNECT additional normally-open switches as shown to monitor door/panel status in series with the integrated Locked State monitoring.
8. ATTACH Rear Mounting Bracket (C) to KS200/KS210 Lock Body (A) using 3 Pan Head Mounting Screws (E). **Diagram 8.**
9. INSTALL Locking Cam (F). Secure with Truss Head Screw (G). **Diagram 9.**

Diagram 7 DPS Activation

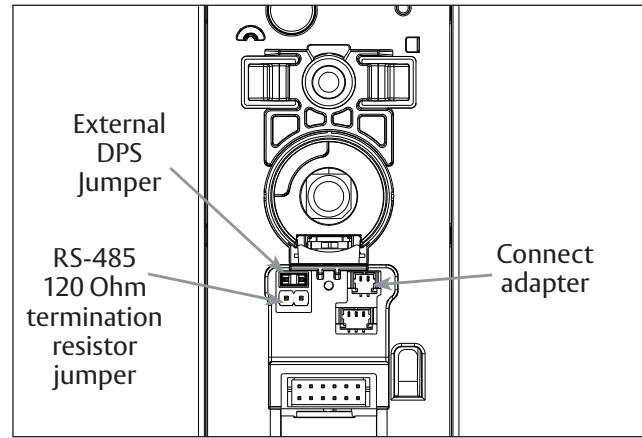

Diagram 8 Attach Rear Mounting Bracket (C) with Pan Head Screws (E)

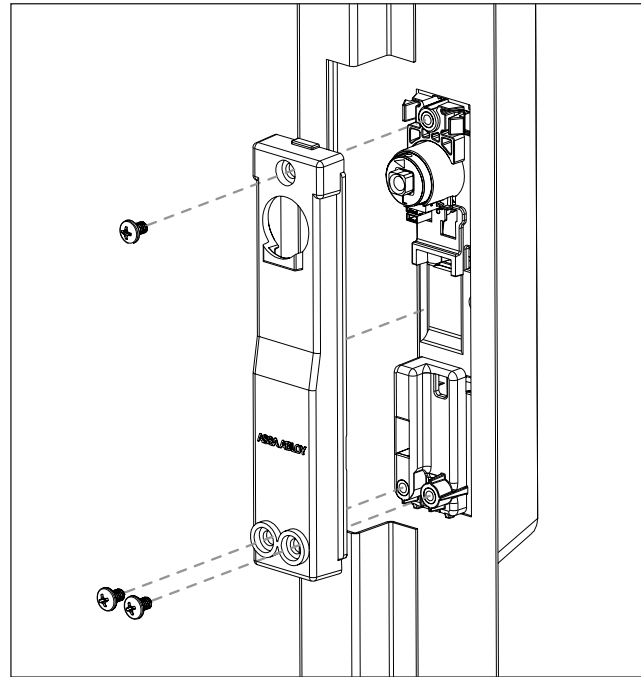
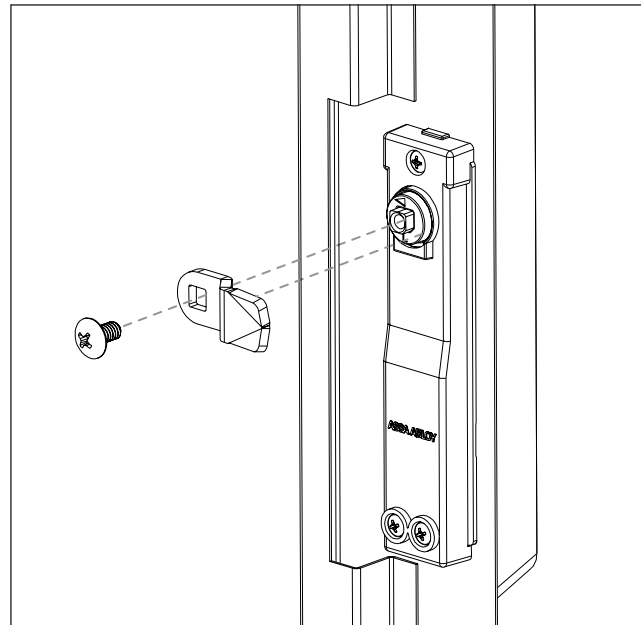

Diagram 9 Install Locking Cam (F) with Truss Head Screw (G)



Cam Selection

NOTE: RE-USE existing cam when possible.

Diagram 10 KS Cam Length Selection

10a BACK

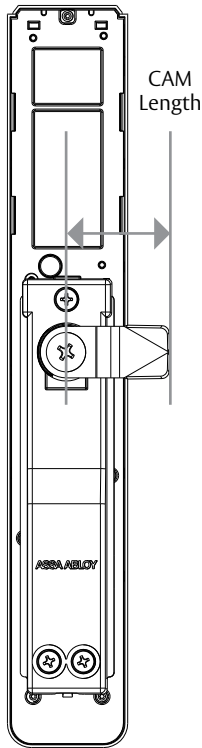

10b SIDE

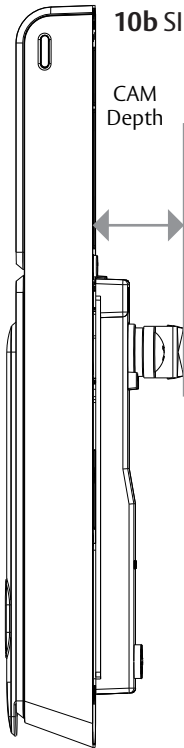

PARTNO.	CAM	CAM LENGTH	CAM DEPTH
Included	38mm – 4 (standard)	1-1/2" [38mm]	1" [25.4mm]
KS-CAM38	38mm – 1 (optional)	1-1/2" [38mm]	1-1/10" [28mm]
KS-CAM45	45mm – 5 (optional)	1-3/4" [45mm]	7/10" [18mm]

Installing SFIC Key Override

NOTE: SFIC blank is required if an SFIC cylinder is not used.
SFIC blank plastic core (SFIC-BC) sold separately.

1. Insert SFIC (H) cylinder and cam into handle. Use spacer for 6-pin SFIC.

Diagram 11 6 or 7-pin SFIC (H)

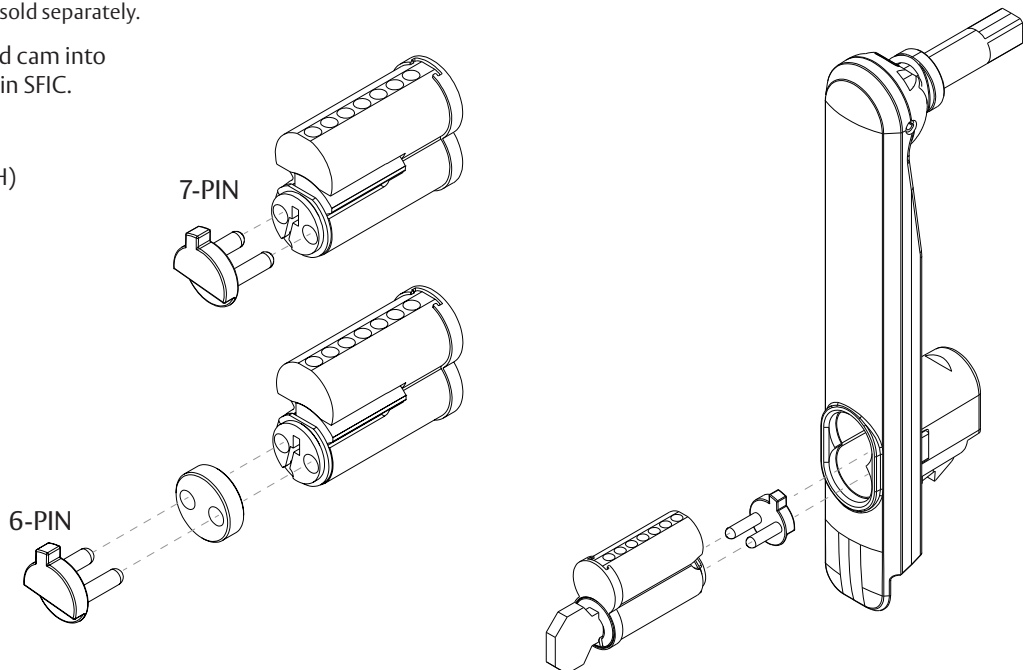

Connections & Wiring



ATTENTION: Installation wiring for the product and wiring methods shall be in accordance with the National Electrical Code (NEC), ANSI/NFPA 70. Observe precautions for handling electrostatic sensitive devices.

Diagram 12 Server Cabinet Wiring Example

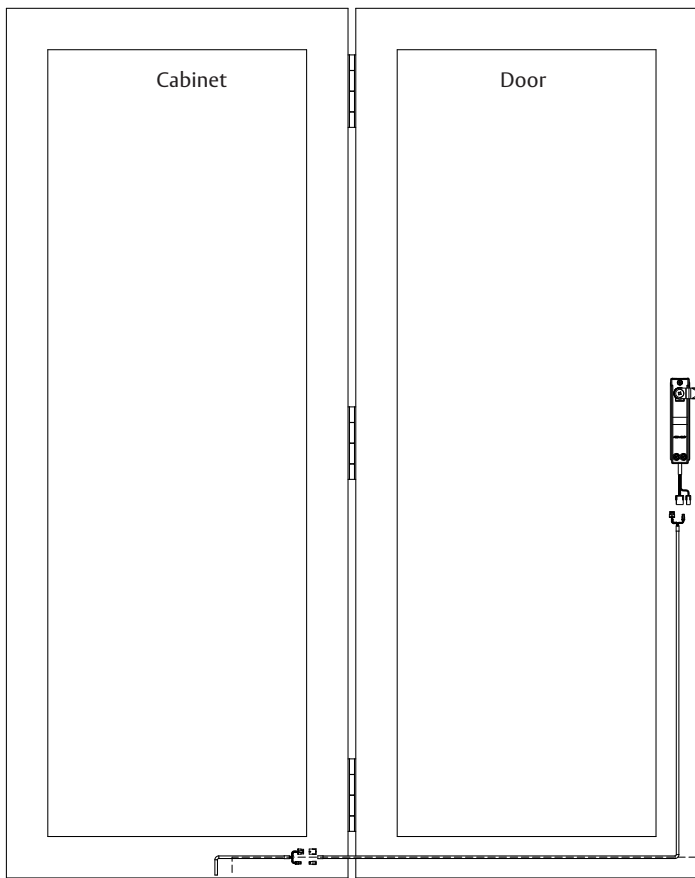

CBL12-QC12, 12 ft System Side Interface Cable to EAC Panel Connection

CBL6-QC12, 6 ft Door Interface Cable

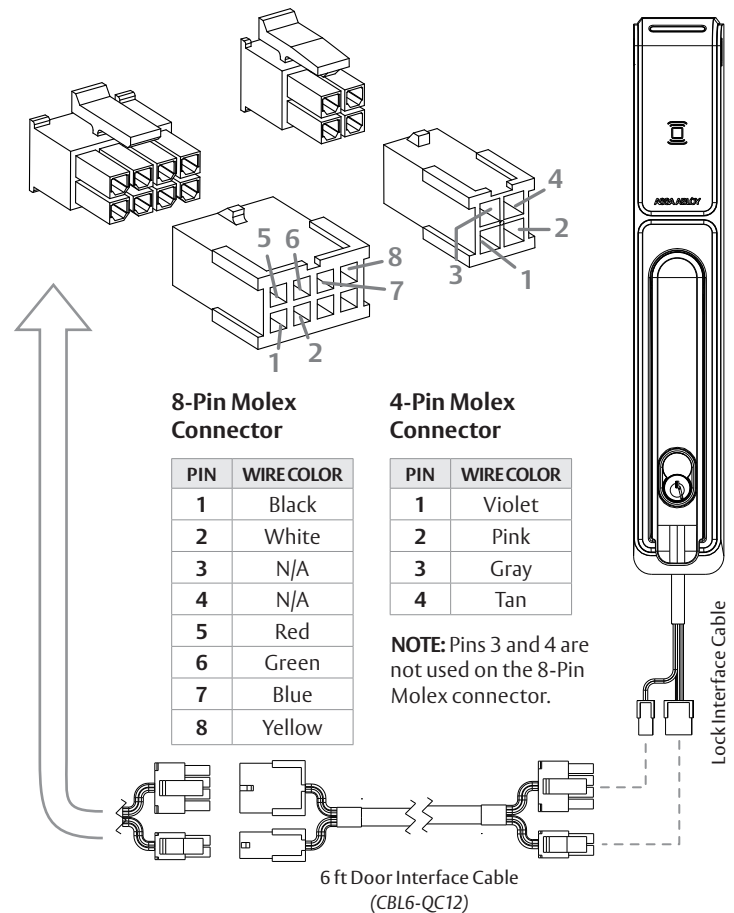

Optional Accessories (Sold Separately)

CBL6-QC12 6 foot x 12-Wire Door Interface Cable (ElectroLynx connectors on both ends). Designed for use with the CBL12-QC12.

CBL12-QC12 12 foot x 12-Wire System Side Interface Cable (ElectroLynx connectors on one end, pins and loose connectors on opposite end). Designed for used with the CBL6-QC12.

Cable & Wire Connections

EAC Integrated Wired: KS200/KS210 Server Cabinet Locks, ElectroLynx Wire Color/Function Assignments

New 4-/8-Pin Molex

Products sold after January 2018

4-PIN MOLEX	WIRE COLOR	FUNCTION	SETTING
1	Violet	Lock Power	COM (-)
2	Pink	Tamper/Locked State/DPS	NO (+)
3	Gray	Lock Power	COM (+)
4	Tan	Tamper/Locked State/DPS	COM (-)

8-PIN MOLEX	WIRE COLOR	FUNCTION	SETTING
1	Black	12 VDC Reader	(-)
2	White	Wiegand Data / OSDP	Data 1 / RS-485-A*
3	N/A	N/A	Not Used
4	N/A	N/A	Not Used
5	Red	12 VDC Reader	(+)
6	Green	Wiegand Data / OSDP	Data 0 / RS-485-B*
7	Blue	LED	Red
8	Yellow	LED	Green

*KS210 OSDP models only

Legacy 10-Pin Molex to 4-/8-Pin Molex

Products sold before December 2017

4-PIN MOLEX	WIRE COLOR	FUNCTION	SETTING
1	Gray	Lock Power	COM (-)
2	Yellow	Tamper/Locked State/DPS	NO (+)
3	Violet	Lock Power	COM (+)
4	Blue	Tamper/Locked State/DPS	COM (-)

8-PIN MOLEX	WIRE COLOR	FUNCTION	SETTING
1	Black	12 VDC Reader	(-)
2	White	Wiegand Data / OSDP	Data 1 / RS-485-A*
3	N/A	N/A	Not Used
4	N/A	N/A	Not Used
5	Red	12 VDC Reader	(+)
6	Green	Wiegand Data / OSDP	Data 0 / RS-485-B*
7	Orange	LED	Red
8	Brown	LED	Green

*KS210 OSDP models only

Optional Quick Connect Guide (Sold Separately)

- CONNECT the Lock Side Interface Cable to the optional 6 ft Door Interface Cable (CBL6-QC12).
NOTE: SEE Server Cabinet Wiring Example, **Diagram 12**.
- CONNECT the Door Interface Cable to the additional optional 12 ft System Side Interface Cable (CBL12-QC12).
NOTE: 18 ft TOTAL wire run when BOTH optional interface cables are utilized.
- RUN the 12 ft System Side Interface Cable, as required.
- ATTACH the included 4-Pin and 8-Pin Female Molex Connectors to the bare wire side of the System Side Interface Cable to extend the interface cable for installations that require longer than 18 ft.

System Side Connections

NOTE: Installation wiring for the product and wiring methods shall be in accordance with the National Electrical Code (NEC), ANSI/NFPA 70.

- CONNECT the bare wires as required to the 3rd party wiring as needed to connect to Electronic Access Control System.
- ENSURE the following power cabling guidelines are followed:

WIRE AWG	SUPPLY VOLTAGE	MAX WIRE RUN (FT)*
20 AWG	12	758
	24	5305
22 AWG	12	477
	24	3336
24 AWG	12	300
	24	2098

*Round trip loss. $V = 2 \cdot I \cdot R \cdot x_{ft}$ $x_{ft} = V / (2 \cdot I \cdot R)$

Round Trip Loss Application Notes

- Data 0 and Data 1 wires for Wiegand may be reused for OSDP. However, standard Wiegand cable may not meet RS485 twisted pair recommendations for maximum data transmission speed and distance.
- For OSDP cable lengths greater than 200 ft [61 m] or EMI interference, install 120 Ohm termination resistor jumper on the KS210 as shown in **Diagram 7**.

Additional OSDP Information

Available at:

assaabloyesh.com/en/tech-info/digital-asset-search/

- Understanding OSDP Implementations (HID/Mercury FAQ)
- How OSDP Is Revolutionizing Access Control Systems (Webinar)
- Why Upgrade to OSDP (Infographic)
- Demystifying OSDP (eBook)

Testing & Commissioning

PRIOR to applying power.

- VERIFY that the SFIC (Small Format Interchangeable Core) cylinder has been installed. If so, verify mechanical actuation of locking cam allowing for emergency override.
- VERIFY that the handle has been returned to the secure/locked state; ensure the door is closed with the locking cam engaging the cabinet and the handle full seated in the lock body.
- APPLY power to the system to verify electronic functionality.
- VERIFY that the LED is illuminated with the correct RED or GREEN color displaying while in the secure state.
- PRESENT a known/valid credential to the RFID target on the face of reader portion (as shown) of the lock to confirm acknowledgment of access granted.
 - » VERIFY that you hear an audible beep when a credential is presented to the reader.
 - » VERIFY that you see the visual LED indicator temporarily change state.
 - » VERIFY that you hear the motor actuate from a lock to unlock state.
- LIFT the handle and ROTATE in the direction of the door hinges to open the cabinet.
 - » VERIFY that the Tamper/Locked State/DPS has changed to a non-secure state.
- RETURN the handle to the secure/locked state; ensure the door is closed with the locking cam engaging the cabinet and the handle full seated in the lock body.
 - » VERIFY that the Tamper/Locked State/DPS has returned to the secure state.

Regulatory

FCC

This device complies with part 15 of the FCC Rules. Operation is subject to the following two conditions: (1) This device may not cause harmful interference, and (2) this device must accept any interference received, including interference that may cause undesired operation.

CAUTION: Any changes or modifications to this device not explicitly approved by the manufacturer could void your authority to operate this equipment.

This equipment has been tested and found to comply with the limits for a Class B digital device, pursuant to part 15 of the FCC Rules. These limits are designed to provide reasonable protection against harmful interference in a residential installation. This equipment generates, uses and can radiate radio frequency energy and, if not installed and used in accordance with the instructions, may cause harmful interference to radio communications. However, there is no guarantee that interference will not occur in a particular installation. If this equipment does cause harmful interference to radio or television reception, which can be determined by turning the equipment off and on, the user is encouraged to try to correct the interference by one or more of the following measures:

- Reorient or relocate the receiving antenna.
- Increase the separation between the equipment and receiver.
- Connect the equipment into an outlet on a circuit different from that to which the receiver is connected.
- Consult the dealer or an experienced radio/TV technician for help.

Model KS200 Contains FCC ID

- JQ6-ICLASSBTM

Model KS200 Contains IC ID

- 2236B-ICLASSBTM

Canada Radio Certification

This device complies with Industry Canada license-exempt RSS standard(s). Operation is subject to the following two conditions: (1) this device may not cause interference, and (2) this device must accept any interference, including interference that may cause undesired operation of the device.

Le présent appareil est conforme aux CNR d'Industrie Canada applicables aux appareils radio exempts de licence. L'exploitation est autorisée aux deux conditions suivantes : (1) l'appareil ne doit pas produire de brouillage, et (2) l'utilisateur de l'appareil doit accepter tout brouillage radioélectrique subi, même si le brouillage est susceptible d'en compromettre le fonctionnement.

CE Marking

Hanchett Entry Systems, Inc. (HES) hereby declares that these proximity readers are in compliance with the essential requirements and other relevant provisions of Directive 2014/53/EU.

Por el presente, HES, Inc. declara que estos lectores de proximidad cumplen con los requisitos esenciales y otras disposiciones relevantes de la Directiva 2014/53/EU.

HES, Inc. déclare par la présente que ces lecteurs à proximité sont conformes aux exigences essentielles et aux autres stipulations pertinentes de la Directive 2014/53/EU.

HES, Inc., por meio deste, declara que estes leitores de proximidade estão em conformidade com as exigências essenciais e outras condições da diretiva 2014/53/EU.

HES, Inc. bestätigt hiermit, dass die Leser die wesentlichen Anforderungen und anderen relevanten Bestimmungen der Richtlinie 2014/53/EU erfüllen.

HES, Inc. dichiara che i lettori di prossimità sono conformi ai requisiti essenziali e ad altre misure rilevanti come previsto dalla Direttiva europea 2014/53/EU.

Warranty

For information on warranty coverage and replacement options, please visit [hesinnovations.com/warranty](https://www.hesinnovations.com/warranty)



techsupport.hes@assaabloy.com
800 626 7590 | [hesinnovations.com](https://www.hesinnovations.com)
10027 S. 51st Street, Ste. 102
Phoenix, AZ 85044 USA

Printed in the U.S.A.
Patent pending and/or patent www.assaabloydss.com/patents
Copyright © 2021-2022, Hanchett Entry Systems, Inc., an ASSA ABLOY Group company.
All rights reserved. Reproduction in whole or in part without the express written permission of Hanchett Entry Systems, Inc. is prohibited. 3080006.023_1